



Rewarding Learning

ADVANCED SUBSIDIARY (AS)
General Certificate of Education
2024

Centre Number

--	--	--	--	--

Candidate Number

--	--	--	--	--

Technology and Design

Assessment Unit AS 1

assessing

Systems and Control or
Product Design



[STE12]

STE12

MONDAY 13 MAY, AFTERNOON

TIME

1 hour.

INSTRUCTIONS TO CANDIDATES

Write your Centre Number and Candidate Number in the spaces provided at the top of this page.

You must answer the questions in the spaces provided.

Do not write outside the boxed area on each page or on blank pages.

Questions which require drawing or sketching should be completed using an H.B. pencil.

All other questions must be completed using black ink only.

Do not write in pencil or with a gel pen.

Answer **both** questions in **either** Section A, B or C.

For all questions requiring calculations, show your working out.

INFORMATION FOR CANDIDATES

The total mark for this paper is 40.

Figures in brackets printed down the right-hand side of pages indicate the marks awarded to each question or part question.

14089.05R



36STE1201

Section A

Electronic and Microelectronic Control Systems

Answer **both** questions in this section.

- 1 (a) The circuit shown in **Fig. 1** has been developed to operate a relay when the single pole single throw (SPST) micro switch Sw has been momentarily closed.

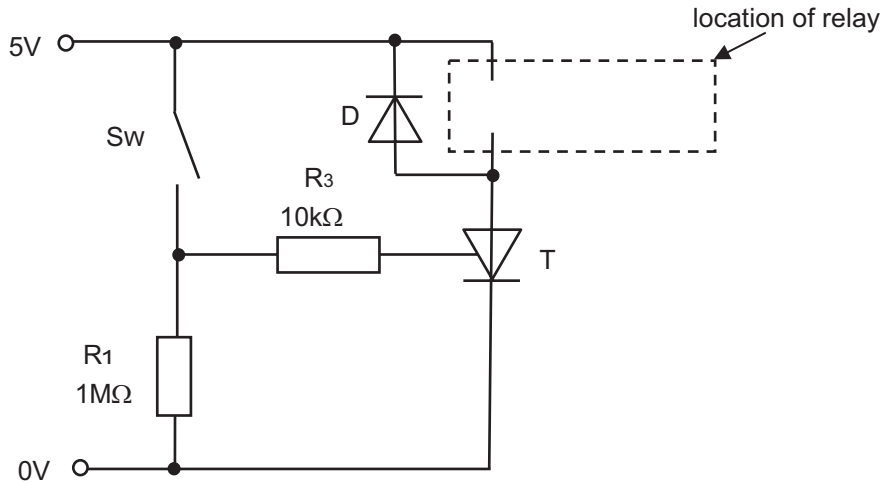

Source: CCEA

Fig. 1

- (i) Describe the distinguishing feature of a micro switch.

[2]



(ii) Explain the operation of the thyristor **T** in **Fig. 1** when the micro switch Sw is briefly closed and opened again. Your answer should make reference to the gate, anode and cathode terminals of the thyristor.

[3]

(iii) As a further development to the circuit shown in **Fig. 1** a means of resetting the circuit is to be added by using either a push to make switch or a push to break switch. On **Fig. 1** add the following:

- a push to make switch connected to act as a reset for the circuit.
 - an **X** to mark where a push to break switch could be connected to act as an alternative reset.
- [2]

(iv) Explain how the diode **D** in **Fig. 1** provides protection from the inductive load caused by the relay.

[2]

[Turn over

14089.05R



36STE1203

- (b) **Fig. 2** shows an LED arrangement and a motor. These two output devices are to be connected to a separate power supply of 12V and operated by a relay as directed in the circuit shown in **Fig. 1**.

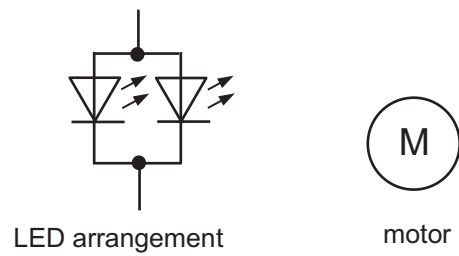

Source: CCEA

Fig. 2

- (i) Calculate the power dissipated, in watts, by the motor shown in **Fig. 2** if it has an operational current of 350 mA.

Candidates need to show their working out in the space below.

Answer _____ W [2]

- (ii) Calculate the required value of a protective resistor in ohms for the LED arrangement shown in **Fig. 2** if each LED operates at a forward voltage of 2.5V and a current of 22 mA.

Candidates need to show their working out in the space below.

Answer _____ Ω [3]



- (c) (i) Complete the circuit in **Fig. 3** below to enable the LED arrangement and motor shown in **Fig. 2** to operate by means of a relay. The LEDs should be illuminated until the thyristor is operational, at which point the motor should turn on and the LEDs should turn off.

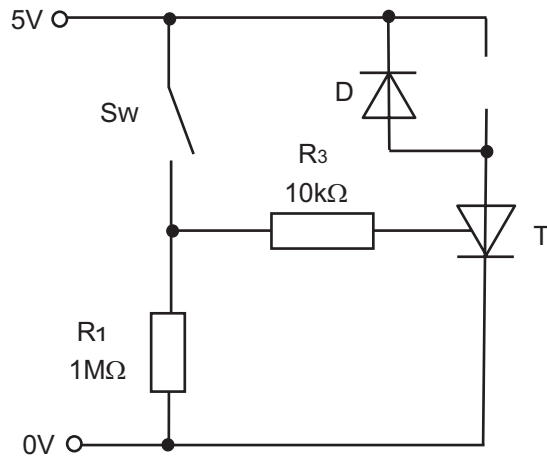

Source: CCEA

Fig. 3

[4]

- (ii) Following production of the circuit shown in **Fig. 3**, testing is to be carried out to check for faults. Explain **one** safety procedure that should be implemented when testing electronic systems.

[2]

[Turn over

14089.05R



36STE1205

- 2 (a) The voltage divider circuit shown in **Fig. 4** is to be used to sense the temperature in a greenhouse. The resistance/temperature characteristic for the thermistor R_{th} is also shown.

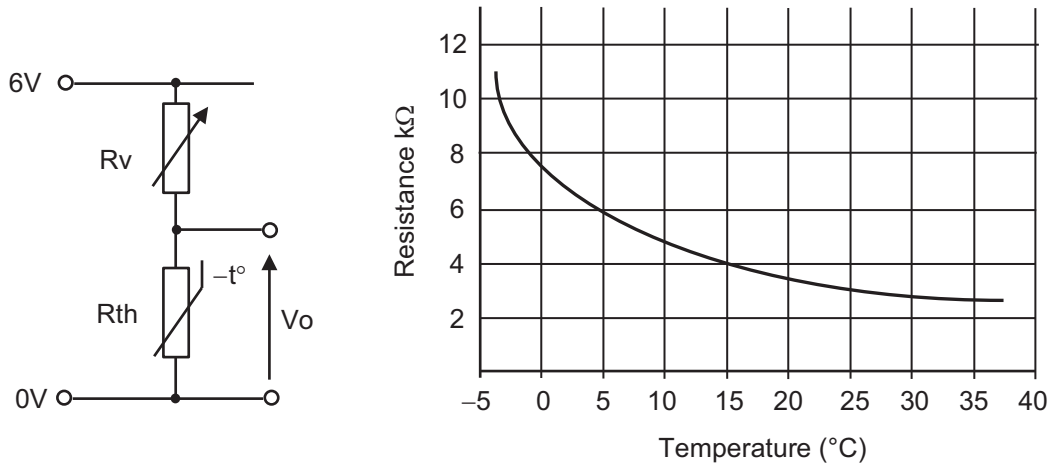

Source: CCEA

Fig. 4

- (i) Explain **one** reason for using a variable resistor rather than a fixed resistor in the voltage divider circuit shown in **Fig. 4**.

[2]

- (ii) Calculate the resistance of R_v , in $k\Omega$, required to obtain a V_o of 2.5 V in **Fig. 4** when the air temperature is 15°C .

Candidates need to show their working out in the space below.

Answer _____ $k\Omega$ [3]



(iii) With reference to the relationship between temperature and the output voltage V_o , explain the effect of swapping the positions of R_{th} and R_v in Fig. 4.

[2]

(b) The symbol for a comparator, which is to be used as part of a system to detect temperature changes in a greenhouse, is shown in Fig. 5. The output voltage V_o from the voltage divider in Fig. 4 is to be used as one of the inputs to the comparator.

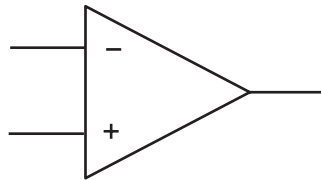

Source: CCEA

Fig. 5

(i) Describe **one** feature of a comparator that makes it suitable for use as part of a system to detect small changes in temperature.

[2]

[Turn over



- (ii) The greenhouse temperature detector based on a comparator is required to produce a positive output voltage to activate an alarm when the temperature drops below a preset level.

Draw the complete circuit design for the greenhouse detector system on **Fig. 6** below by adding the following:

- a $\pm 6\text{V}$ dual power supply
- both inputs as required for the comparator to operate
- a buzzer driven by a transistor connected to the output of the comparator.

[5]

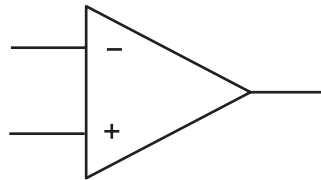

Source: CCEA

Fig. 6



(c) As a further development, the buzzer on the greenhouse temperature detector will repeatedly sound on and off when the comparator detects a low temperature. This will be achieved by inserting a 555 timer between the comparator and the buzzer driver as shown in **Fig. 7**.

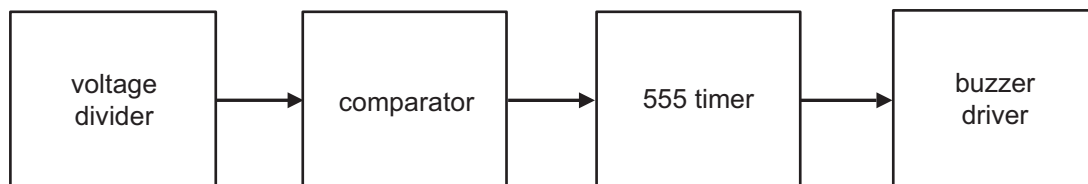

Fig. 7

(i) State if the system shown in **Fig. 7** can be considered as on/off or continuous and justify your answer.

Answer _____ [1]

Justification _____

_____ [2]

[Turn over



- (ii) The 555 circuit to be used is shown in **Fig. 8**. Calculate the required value of the capacitor C , in microfarads (μF), to achieve an output frequency of 2 hertz if $R_1 = 18\text{ k}\Omega$ and $R_2 = 27\text{ k}\Omega$.

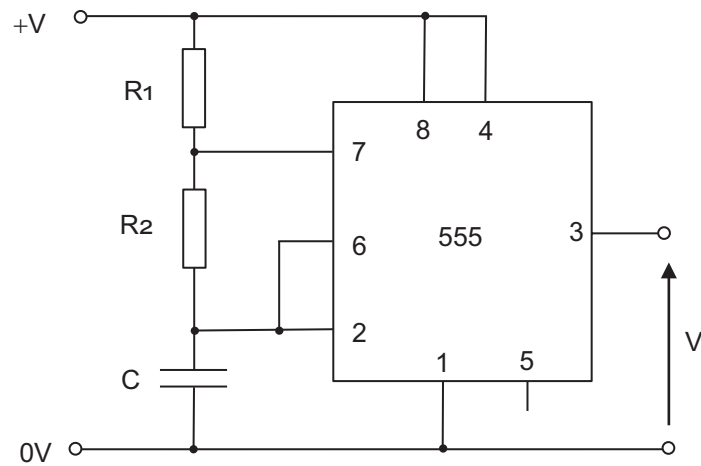

Source: CCEA

Fig. 8

Candidates need to show their working out in the space below.

Answer _____ μF [3]





BLANK PAGE

DO NOT WRITE ON THIS PAGE

(Questions continue overleaf)

14089.05R

[Turn over



36STE1211

Section B

Mechanical and Pneumatic Control Systems

Answer **both** questions in this section.

- 3 **Fig. 9** shows a prototype control system for an exhibit in a museum display. The exhibit rotates on a large turntable with a pneumatic system that causes the animatronic dinosaur to lunge forward and open its jaws when it is facing the viewing area.

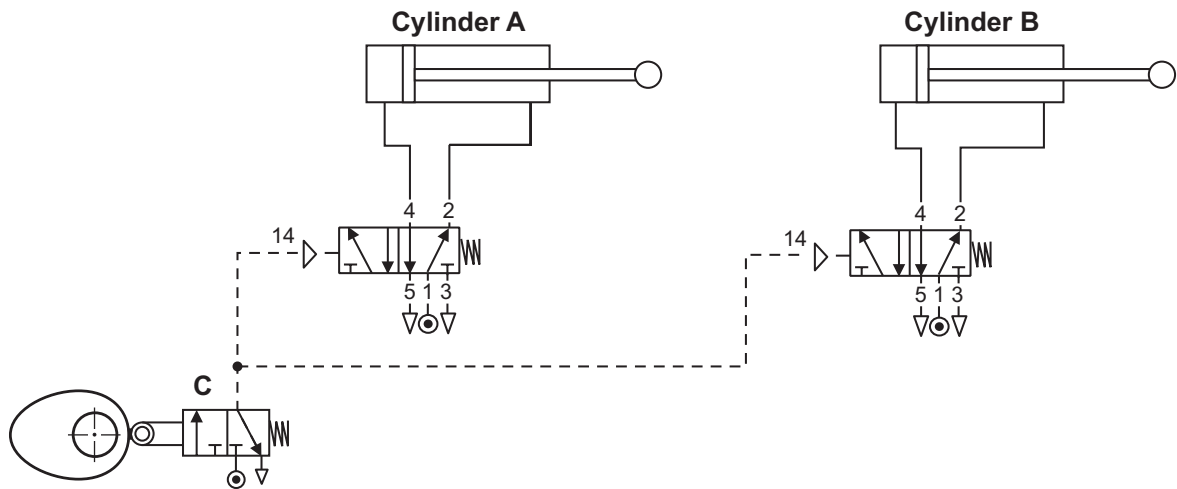

Fig. 9

Fig. 10 shows the skeleton of the exhibit before and after the pneumatic circuit is activated.

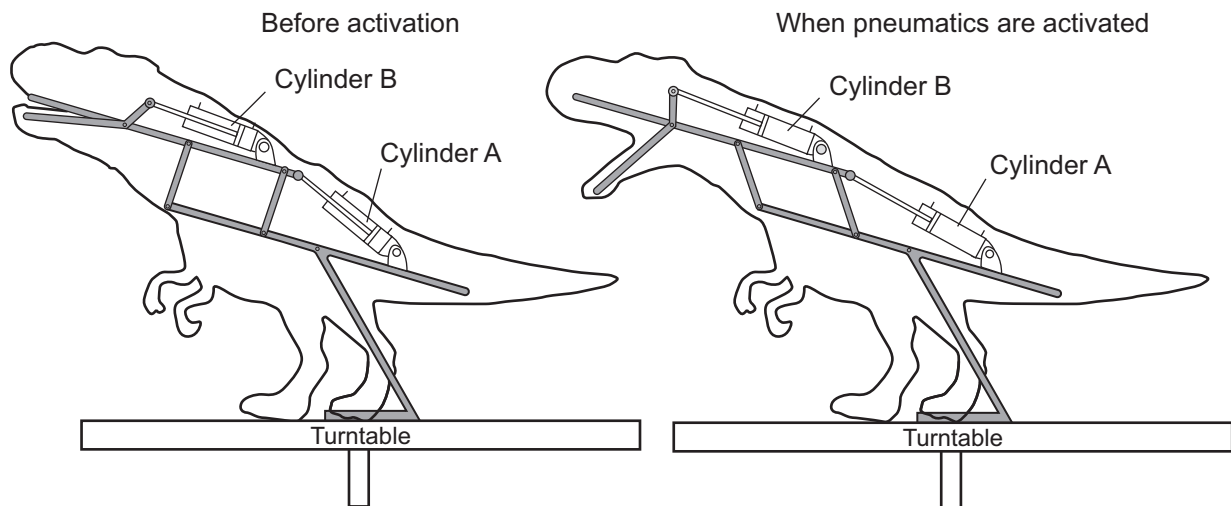

Fig. 10



(a) Name the mechanism which activates the roller on three port valve **C** shown in **Fig. 9**.

[1]

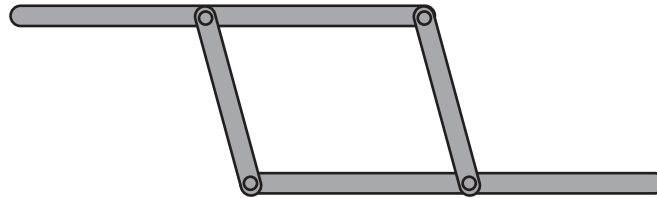

Fig. 11

(b) The linkage system shown in **Fig. 11** is used to control the motion of the dinosaur exhibit.

State the name of this linkage.

[1]

[Turn over



(c) Explain the three main stages in conditioning compressed air before it can be used in a pneumatic system.

1. Filtration

[2]

2. Pressure regulation

[2]

3. Lubrication

[2]



(d) During testing it was found that the operation of the pneumatic circuit in **Fig. 9** should be changed to improve the realism of the motion of the exhibit.

Complete the circuit in **Fig. 12** below so that upon activation of the roller trip at the 5 port valve **D** the circuit will operate in the sequence **A+**, **B+** and upon release of the roller trip 5 port valve **D** the circuit will operate in the sequence **B-**, **A-**.

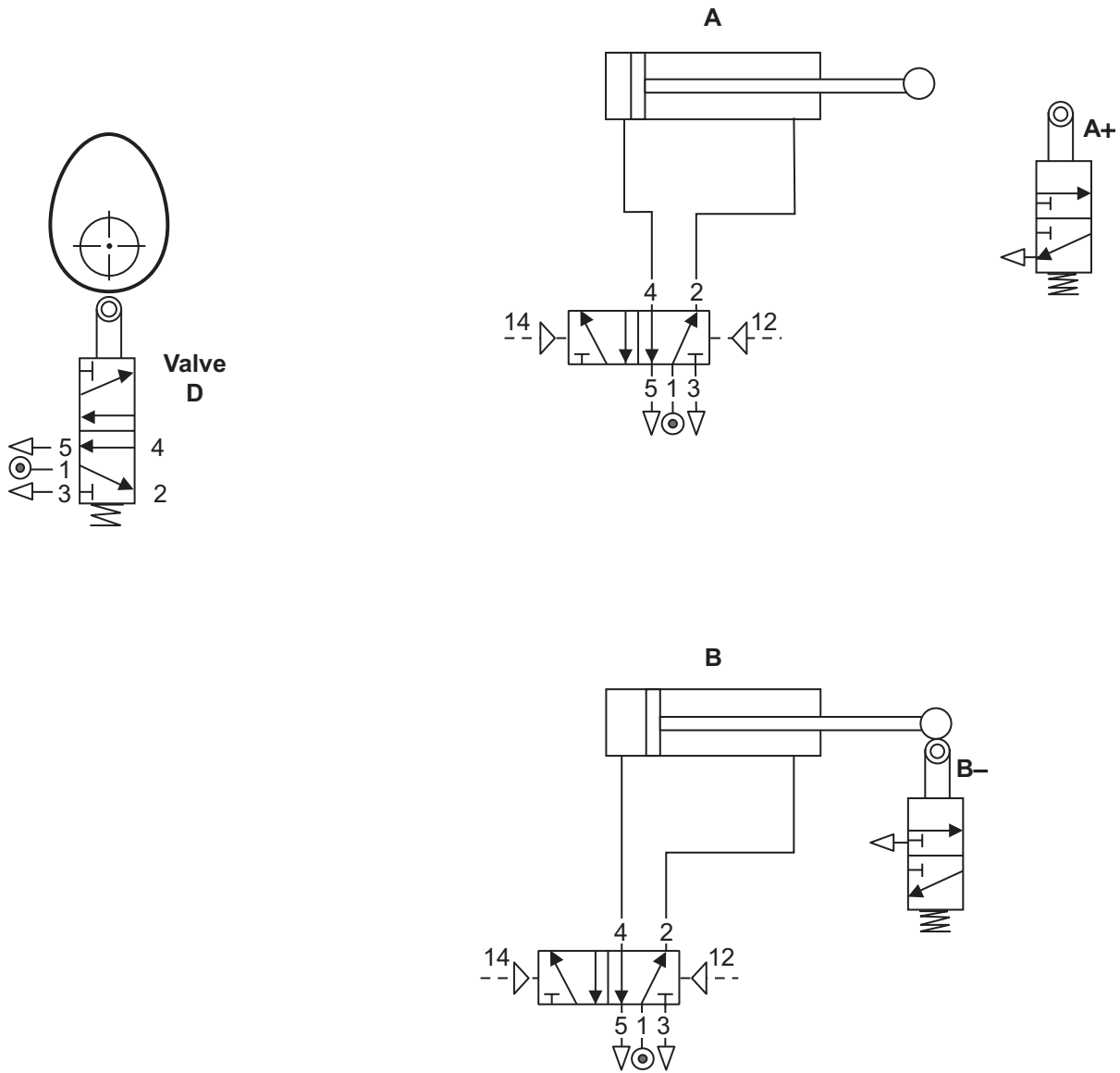

Fig. 12

[6]

[Turn over

14089.05R



36STE1215

(e) The museum exhibit is mounted on a large revolving turntable which is driven by an electric motor coupled to a drive train shown below in **Fig. 13**.

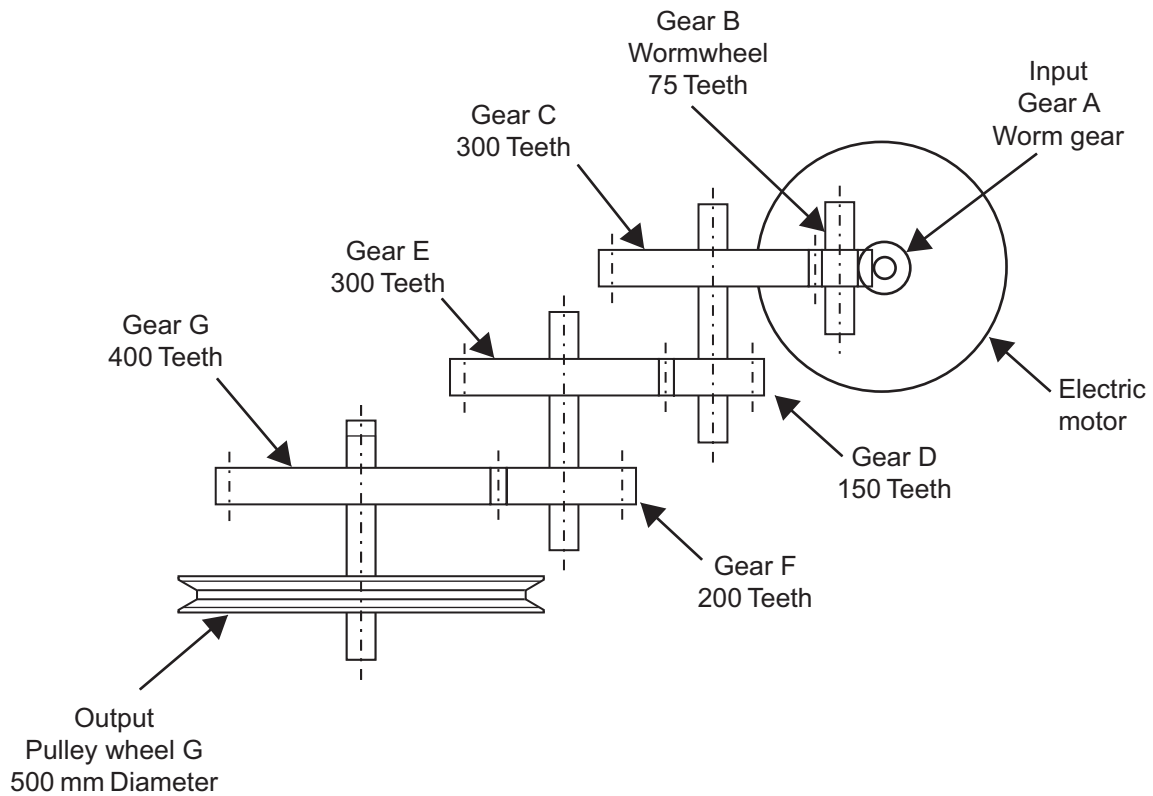

Fig. 13

Calculate the velocity ratio between gear A and pulley wheel G.

Candidates need to show their working out in the space below.

Answer _____ [5]



(f) Calculate the output speed of the drive train if the input speed of the worm gear is 3000 RPM.

Candidates need to show their working out in the space below.

Answer _____ RPM [1]

[Turn over

14089.05R



36STE1217

- 4 **Fig. 14** shows a clamping device operated by a pneumatic cylinder. The cylinder is supplied with an air pressure of 0.2 N/mm^2 , has a piston diameter of 40 mm and a piston rod diameter of 15 mm.

(a) (i) Calculate the force provided by the cylinder during the outstroke.

Assume $\pi = 3.14$.

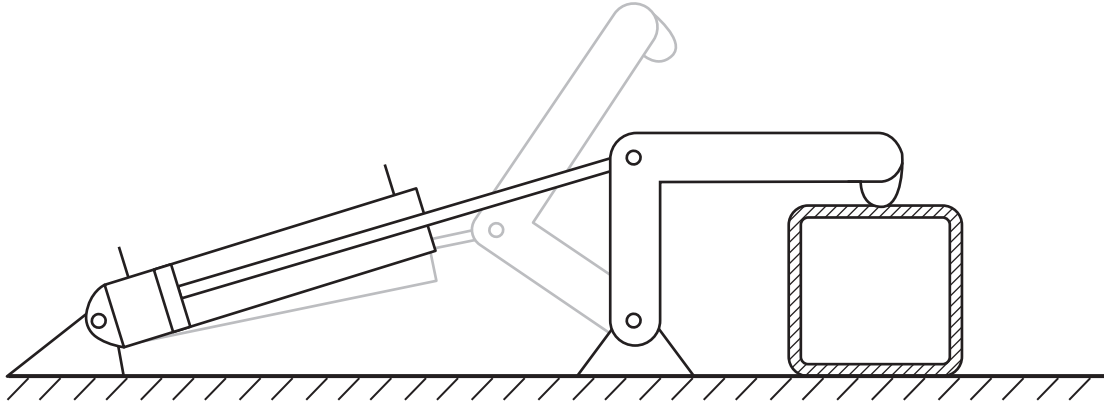

Fig. 14

Candidates need to show their working out in the space below.

Answer _____ N [4]



A cylinder is arranged in a different configuration to clamp a workpiece as shown in **Fig. 15**.

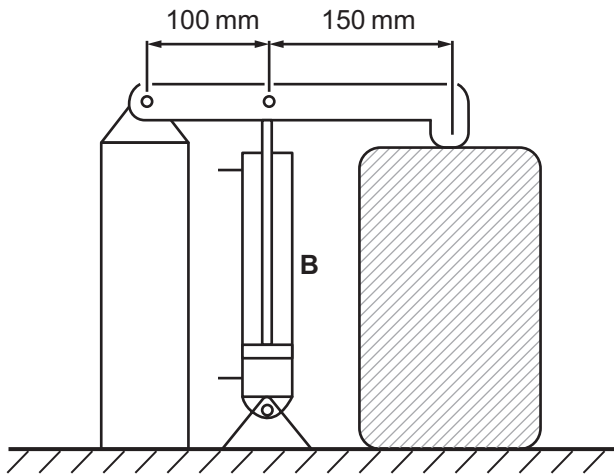

Data for cylinder B	
Diameter of piston D	38 mm
Diameter of piston rod d	10 mm
Air pressure	0.2 N/mm^2
π	3.14

Fig. 15

(ii) State the class of lever shown in **Fig. 15**.

Answer _____ [1]

(iii) Calculate the force produced by cylinder **B** in **Fig. 15** when it is activated to **instroke** with an air pressure of 0.2 N/mm^2 .

Assume $\pi = 3.14$.

Candidates need to show their working out in the space below.

Answer _____ [4]

[Turn over



(iv) A lever used in a clamping mechanism is shown in Fig. 16.

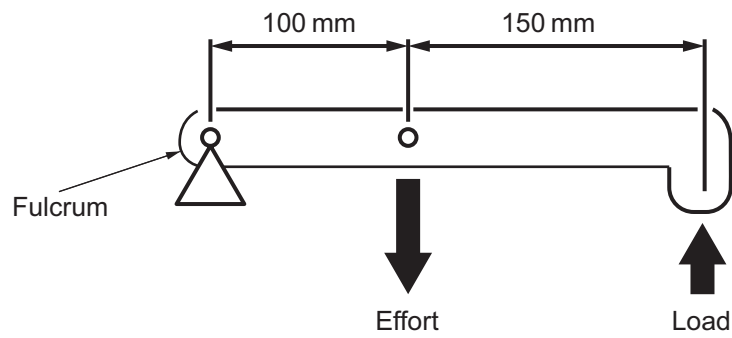

Fig. 16

Calculate the mechanical advantage produced by the lever shown in Fig. 16.

Candidates need to show their working out in the space below.

Answer _____ [1]

(b) Complete Fig. 17 with an annotated sketch of a suitable mechanism which could connect the motor shaft A to output shaft B with a velocity ratio of 2.0.

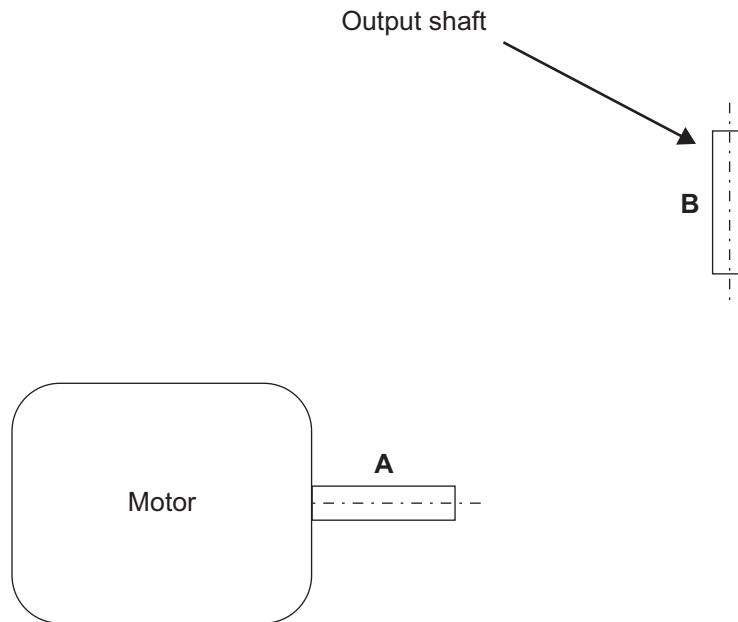

Fig. 17

[3]



(c) Complete the circuit shown in **Fig. 18** so that activation of the 3/2 valve **A** causes the single acting cylinder **B** to operate with a time delay on the outstroke.

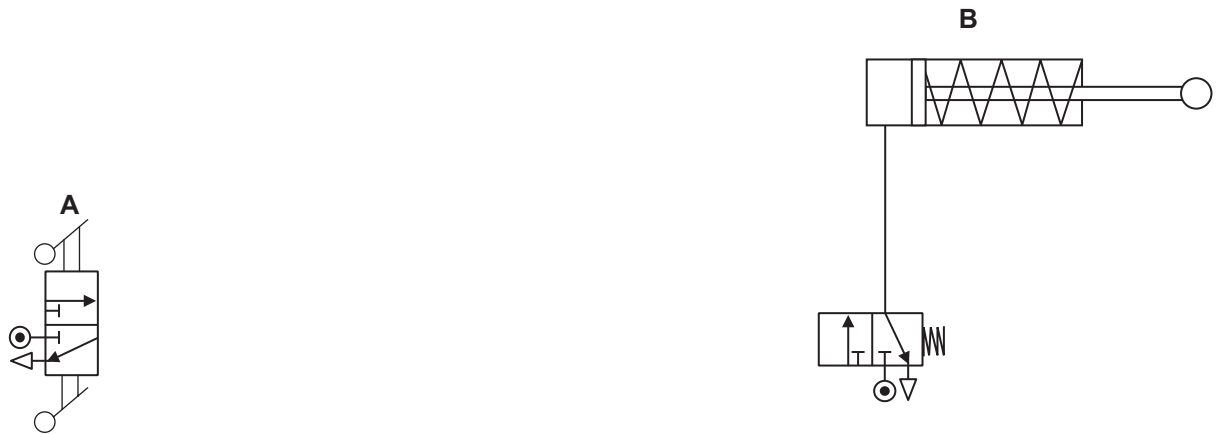

Fig. 18

[3]

(d) Explain **one** safety consideration when working with pneumatic systems and explain **one** safety consideration when working with mechanical systems.

Pneumatics

[2]

Mechanical

[2]

[Turn over



Section C

Product Design

Answer **both** questions in this section.

- 5 A local company that designs and manufactures guitars provides a range of models to suit the customer's skill level and preferences. **Fig. 19** shows one of the models, a classic junior guitar aimed at the young beginner.



Source: Principal Examiner

Fig. 19



(a) When conducting research for the guitars a survey was used by the company.

Explain what is meant by a survey.

[2]

(b) Before commencing production of the guitars the product must comply with British Standards and employee and consumer safety.

(i) State **two** characteristics associated with British Standards.

1. _____

_____ [1]

2. _____

_____ [1]

(ii) Distinguish between employee and consumer safety.

[2]

[Turn over

14089.05R



36STE1223

(c) To assist in the planning for manufacture of the guitars a flow process chart is to be used.

Briefly outline **two** characteristics associated with a flow process chart.

1. _____ [1]

2. _____ [1]

(d) The company uses quick response manufacture (QRM) as the preferred method to organise the design and production for all the guitar products it produces.

Briefly outline **two** characteristics associated with QRM.

1. _____ [1]

2. _____ [1]

(e) A prototype model of the guitar is to be manufactured by laminating the wood.

Explain how the curved portion of the guitar shown in **Fig. 19** could be manufactured using the laminating process.

_____ [2]



(f) Throughout the design process, designers from the company engaged with the client by using formative and summative evaluation techniques.

Distinguish between formative and summative evaluation techniques.

[2]

[Turn over

14089.05R



36STE1225

- (g) With reference to **Fig. 20** below and using the blank A4 pro forma (answer number **5(g)**) complete the following using detailed annotated sketches:

An appropriate compact design for a stand which will hold the guitar at approximately 80 mm off the floor and at an angle of approximately 60° to the floor. Your design must be able to be quickly and easily folded and unfolded for use and should minimise the use of materials and storage space.

[6]



Source: Principal Examiner

Fig. 20





Pro forma answer page (answer no. 5 (g))

[Turn over

14089.05R



36STE1227

6 Fig. 21 shows a photograph of a garden vacuum.



Fig. 21

A company that designs and manufactures a wide range of garden products such as the garden vacuum shown in Fig. 21 is keen to adopt a continuous improvement approach.

(a) Explain what is meant by the term continuous improvement and give **one** reason why the company would want to adopt this approach.

[2]

Reason

[1]



(b) To help generate ideas for the garden vacuum the company uses the technique of attribute analysis.

With reference to **Fig. 21** explain how attribute analysis could be used to help generate ideas for the garden vacuum.

[2]

(c) Prior to production of the garden vacuum a work order was created.

Explain what is meant by a work order.

[2]

[Turn over

14089.05R



36STE1229

(d) An idea that emerged during the development of the product was to manufacture the vacuum tube shown in **Fig. 21** from carbon fibre reinforced plastic (CFRP).

(i) State **two** properties associated with CFRP which would make it suitable for the vacuum tube.

1. _____

2. _____
_____ [2]

(ii) State **one** reason why CFRP may be considered as an unsuitable material for the vacuum tube.

_____ [1]

(e) The company has developed a new logo and plans to manufacture a new metal sign for the front of its business premises. This metal sign is to be manufactured by using a water jet cutting process.

With the use of an annotated sketch explain the water jet cutting process.

[4]



(f) After discussing the intellectual property rights for the garden vacuum the design team decided to apply for a registered design.

Briefly outline **two** specific characteristics associated with a registered design.

1. _____

2. _____

_____ [2]

[Turn over

14089.05R



36STE1231

(g) The company plans to develop the vacuum tube to make the product easier for the user to operate. **Fig. 22** shows a photograph of the garden vacuum and a cross sectional view on X–X of the vacuum tube.

Using the blank A4 pro forma (answer number **6(g)**) use detailed annotated sketches to produce **one** possible solution for the following:

A suitable design that can be securely attached to the bottom of the vacuum tube to ensure that the tube will remain at least 50 mm off the ground during use, whilst maintaining the manoeuvrability of the product.

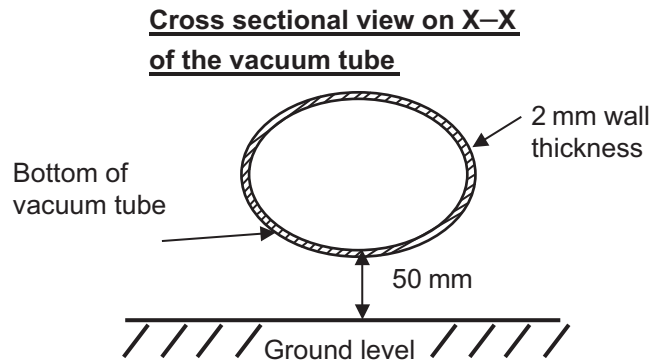

Fig. 22

[4]





Pro forma answer page (answer no. 6 (g))

14089.05R



36STE1233

THIS IS THE END OF THE QUESTION PAPER

14089.05R



36STE1234





BLANK PAGE

DO NOT WRITE ON THIS PAGE

14089.05R



36STE1235

DO NOT WRITE ON THIS PAGE

For Examiner's use only	
Question Number	Marks
1	
2	
3	
4	
5	
6	

Total Marks	
--------------------	--

Examiner Number

Permission to reproduce all copyright material has been applied for.
In some cases, efforts to contact copyright holders may have been unsuccessful and CCEA will be happy to rectify any omissions of acknowledgement in future if notified.

STE12/6
290466

